

# INSTRUCTION MANUAL

SYNCHRO CHECK RELAY

CSY-96

Thank you for purchasing DAIICHI ELECTRONICS product.  
Read this instruction manual carefully before installation, wiring, and using this product.

## Safety precautions

### ■ Environment conditions

Please be sure to use this product in a place that meets the following conditions. In places that do not meet this condition, malfunctions and failures, and performance and product life may be reduced.

- Within the range of ambient temperature 0 to 55°C, humidity 5 to 95% RH.
- Environment with low corrosive gas, dust, salt and oil smoke. (Corrosive gas : SO<sub>2</sub> / H<sub>2</sub>S, etc.)
- Environment that is not affected by vibration or shock.
- Environment with less external noise.
- Altitude 1000m or less.

### ■ Outdoor use conditions

- These products are not a dustproof, waterproof, and splash proof construction. Please avoid the place with much dust. Moreover, please install in the place not exposed to rain or water drop.
- Please do not install in the place where sunlight hits directly. Discoloration and degradation of a name plate, and deformation of the case by the surface temperature rise may occur.

### ■ Mounting and wiring

Please refer to this instruction manual for mounting and the wiring.

The installation and wiring must be carried out by a qualified person only.

- There is no function which checks the balance of phase sequence detection and each three phase voltages.
- Separate power circuit and control / signal circuit wirings, and prevent noise around the product.
- Connect grounding wire to grounding terminal (terminal 9).

 <b>CAUTION</b>	<ul style="list-style-type: none"> <li>● Please refer to connection diagram for the wiring.</li> <li>● Please avoid hot line work.</li> <li>● Please use an electrical wire size suitable with the rated current.</li> <li>● Please check the tightening of the screw.</li> <li>● Terminal cover must be attached after the installation and wirings.</li> </ul>
--	--

### ■ Preparation before use and precautions during operation

This product must be set before use. Please set correctly after reading this instruction manual.

- Do not touch the product under operation condition.
- Please use an auxiliary power range in 100/110V AC (85 to 127V) or 100/110V DC (88 to 143V).  
Use outside the power supply voltage range will malfunction.
- After the synchronization check, please make no auxiliary supply and AC input (bus voltage, generator voltage) no voltage.  
However, there is no trouble with continuous energization.
- Contact capacity of control signal (Optical MOS-FET relay) is 100V DC, 100mA.  
Please attach the element which absorbs back starting voltage generated at the time of opening and closing in the coil of the relay used outside.

### ■ Setting

Setting must be carried out carefully in accordance with the instruction manual.

The followings must be followed during the setting.

- Tighten the switch cover during operation and after completion of setting.
- The auxiliary power must be off before the setting.
- In case of incorrect setting, the control function will stop and an error will be displayed.  
Please change the setting within the allowable setting range.

**■ Maintenance and inspection**

This product should be maintained and inspected periodically with reference to the instruction manual. If any abnormality is found, please refer to Troubleshooting.

- Inspection in energized state is dangerous.
- Do not touch input and auxiliary power terminals while energized.
- Please check a connection diagram, in case you check the voltage of input and auxiliary supply.
- There are no replacement parts required for regular maintenance.
- Please check the next item periodically.
  - (1) Please confirm that each indication displays it definitely. (POWER LED, Status display LED, Digital display).
  - (2) Please check that ALARM LED is not lights, and that the ALARM signal is not outputting.
  - (3) Please check whether there are discoloration of LED and damage of appearance.
  - (4) Please check whether there are looseness of wiring and looseness of a captive screw.
- If dust has adhered to this product, please wipe off lightly with the dry soft cloth. Please do not use the organic solvent, chemicals, cleaners, etc., such as an alcohol, for cleaning.

**■ Storage**

Please store in a place that meets the following conditions.

- The ambient temperature within  $-10$  to  $+70$  °C (storage temperature).
- Daily average temperature  $40$  °C or less.
- Location corresponding to the usage environment and use conditions.
- Aluminum electrolytic capacitors are used in products. Please energize the power supply within one year after purchase.

**■ Countermeasures against troubles**

If trouble occurs within the warranty period, DAIICHI ELECTRONICS will repairs this product.

**■ Disposal**

Please dispose this product as industrial waste (non-combustible).  
Mercury parts and a nickel-cadmium battery are not used for this product.

**■ Warranty period**

The warranty period of the product is one year after the date of delivery.

## Content

Safety precautions .....	1
1. Product outline .....	4
2. Features of product .....	4
3. Function .....	4
4. Handling explanation	
4.1 Display .....	5
4.2 Outline dimension .....	6
4.3 Installation and removal of products .....	6
4.4 Wiring .....	7
4.5 Operating precautions .....	8
4.6 How to set up .....	8
4.7 Setting example .....	10
5. Control function	
5.1 Control range .....	10
5.2 Control output and description .....	10
6. Operation overview .....	11
7. Test .....	12
8. Specification and performance	
8.1 Specification .....	12
8.2 Performance .....	13
9. Principle of operation	
9.1 Block-diagram .....	14
9.2 Explanation of operation .....	14
10. Maintenance	
10.1 Error description .....	15
10.2 Troubleshooting .....	15

## 1. Product outline

This product is a synchronous check relay with a synchronous verification display developed for synchronous closing between a bus and a generator and between a grid and a grid.

This product can be used as a fail-safe for automatic synchronization and manual synchronization.

## 2. Features of product

- (1) Synchronous check relay and synchroscope are integrated in one unit.
- (2) Synchronization check signal can be set from  $\pm 3^\circ$  to  $\pm 35^\circ$ .
- (3) Voltage difference and frequency difference can be detected and set.
- (4) Equipped with dead bus detection function.
- (5) Lightweight, compact and space-saving.

## 3. Function

- (1) Voltage balancing detection.  
When the voltage between the bus and the generator or between the grid and the grid is within the specified range ( $\Delta V$ ), the LED for the signal within the voltage difference set value lights up.
- (2) Frequency balance detection.  
When the frequency between the bus-bar and the generator or between the system and the system is within the specified range ( $\Delta F$ ), the LED for the signal within the frequency difference setting value lights up.
- (3) Synchronization check signal.  
When the voltage difference  $\Delta V$  and frequency difference  $\Delta F$  between the bus-bar and the generator or between the system and the system are within the specified value and the phase difference is within  $\pm \Delta \phi$ , a contact signal is output and the LED lights.
- (4) Dead bus detection.  
When the voltage between the bus-bus and the generator or between the system and the system, either one or both of which is 47% or less than the rated voltage, the a-contact signal is output and the LED lights. A return becomes more than 50%.
- (5) Alarm detection.  
When a device error (ROM, RAM, A/D error, etc.) or setting error occurs, a contact signal is output and the LED lights.
- (6) Setting function.  
Voltage difference, frequency difference, and phase difference can be set.

## 4. Handling explanation

## 4.1 Display

Disposition of display

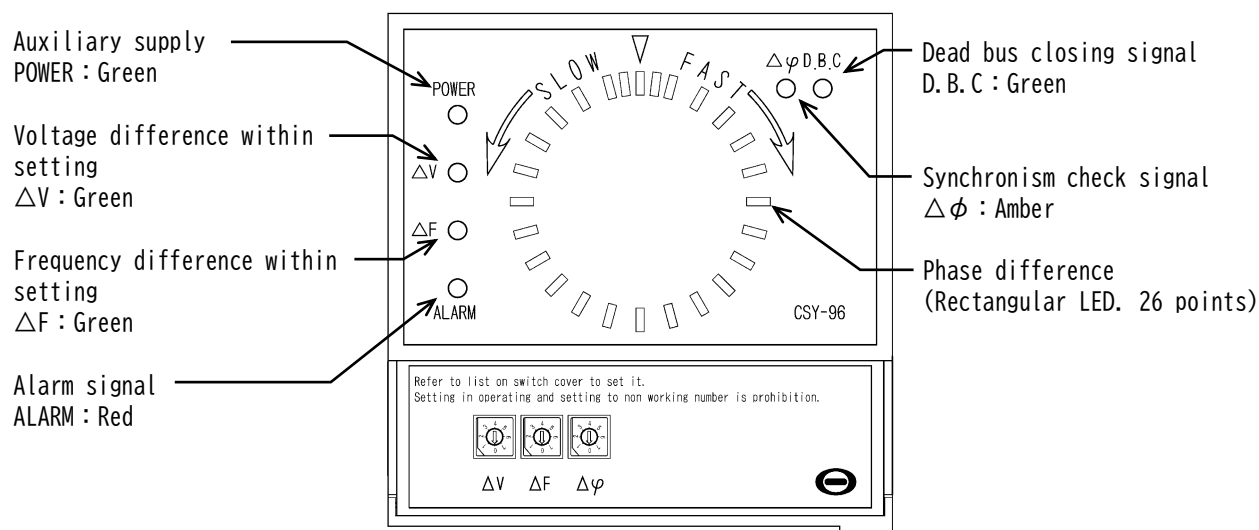

(Measurement display)

Phase difference display. (Rectangular LED : Amber. However, synchronism point is green.)

Display the phase difference of the bus voltage and generator voltage.

24 points of  $15^\circ$  interval, and 2 points of  $7.5^\circ$  interval is around synchronism point.

Direction of rotation.

SLOW : If the frequency of the generator is lower than the bus line.

FAST : If the frequency of the generator is higher than the bus line.

(Status display)

- (1) Display of auxiliary supply (POWER). (Green LED)  
The LED lights when auxiliary supply is apply.
- (2) Display of synchronism check signal ( $\Delta\phi$ ). (Amber LED)  
The LED lights when synchronism check signal ( $\Delta\phi$ ) is output.
- (3) Display of dead bus closing signal (D.B.C). (Green LED)  
The LED lights when dead bus closing signal (D.B.C) is output.
- (4) Display of voltage difference within setting ( $\Delta V$ ). (Green LED)  
The LED lights when the voltage difference between the bus and generator is within the set value ( $\Delta V$ ).
- (5) Display of frequency difference within setting ( $\Delta F$ ). (Green LED)  
The LED lights when the frequency difference between the bus and generator is within the set value ( $\Delta F$ ).
- (6) Alarm signal (ALARM) display (Red LED)  
The LED lights when equipment error occurs (ROM error, RAM error, A/D error).  
And the LED lights when a setting error occurs.

4.2 Outline dimension

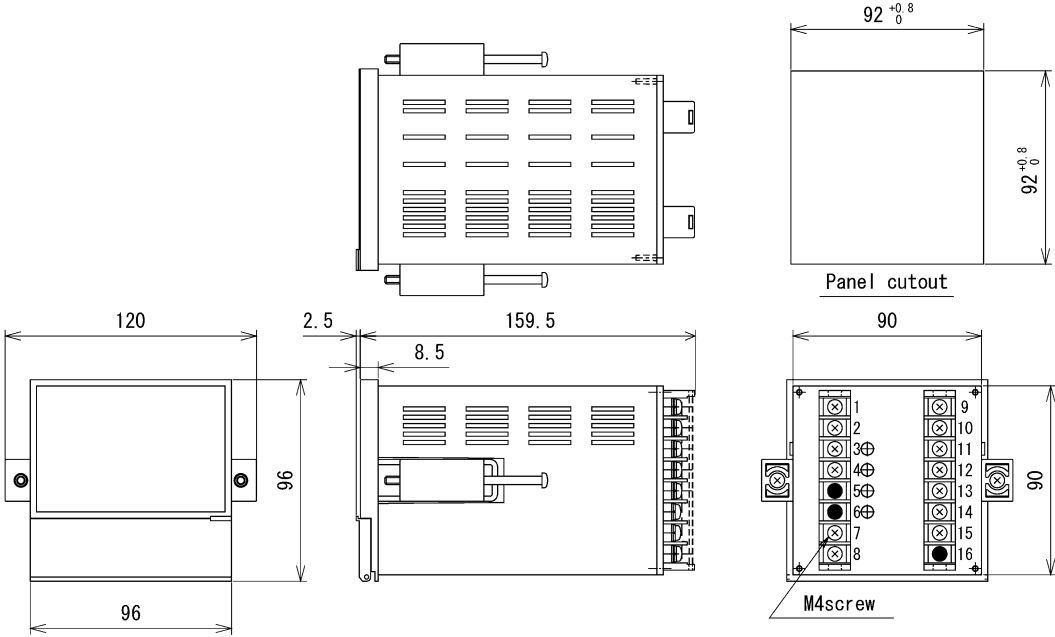

<Note> Design the panel cutout so that the distance between this unit and adjacent devices is 27mm or more. The thickness of the mounting panel should be 8 mm or less.

■ Precautions for installation

Installation should be done by a person who has specialized skills such as electrical work and electrical wiring. Please install indoors in a place with low mechanical vibration, dust, and corrosive gas. And, please select indoors that are not affected by a strong electromagnetic field by large current bus, saturable reactor etc. in the vicinity. There is no restriction on mounting position.

<Caution> Applying vibration or shock during installation may cause failure, so please install carefully.

4.3 Installation and removal of products

(1) How to install the product

- ① Insert the main body from the front of the panel.
- ② On the back side of the panel, attach the attached install tool to the mounting hole on the side of the body. (Right and left, 2 places) (Place the claw of the fixture in the hole of the main body and pull it in the terminal side)
- ③ Tighten the mounting screws with a Phillips screwdriver to secure the unit. (Right and left, 2 places) Tightening torque : 0.59 to 1.08N·m (6 to 11kg·cm). Recommended tightening torque : 0.88N·m (9kg·cm) (When tightening the screws, fasten the screws alternately instead of tightening one side only. When installing in a place subject to vibration, please use screw lock agent. )

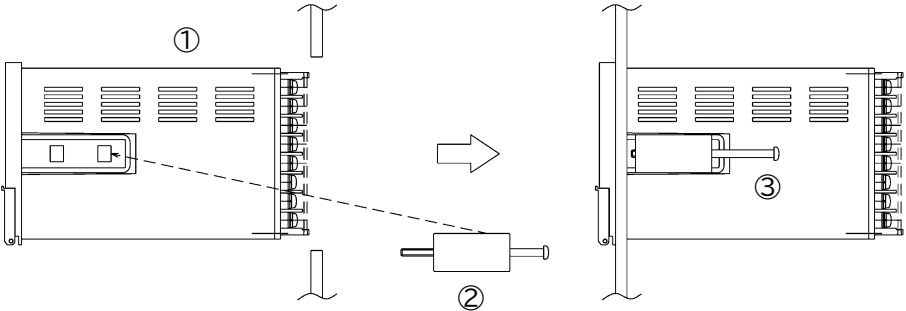

(2) How to remove the product

Perform the reverse work to the mounting method. If it is difficult to remove the fixture, please remove it as follows. After loosening the screw, press the screw head in the direction of the main body (①) and push it out to the front (②)

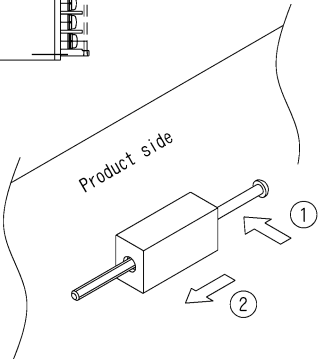

4.4 Wiring

Be sure to check the phase between the LINE side and the GENERATOR side.

(1) For AC input 110V AC

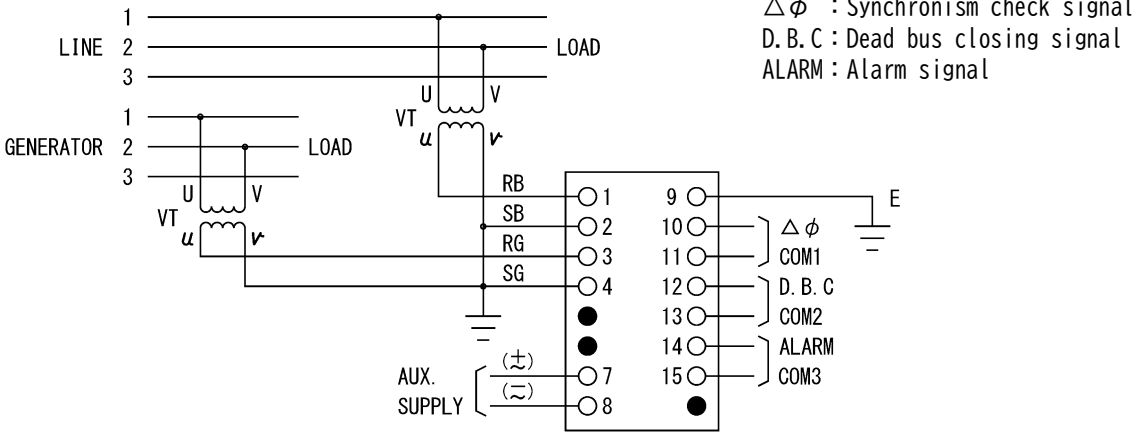

(2) For AC input 110/√3V AC

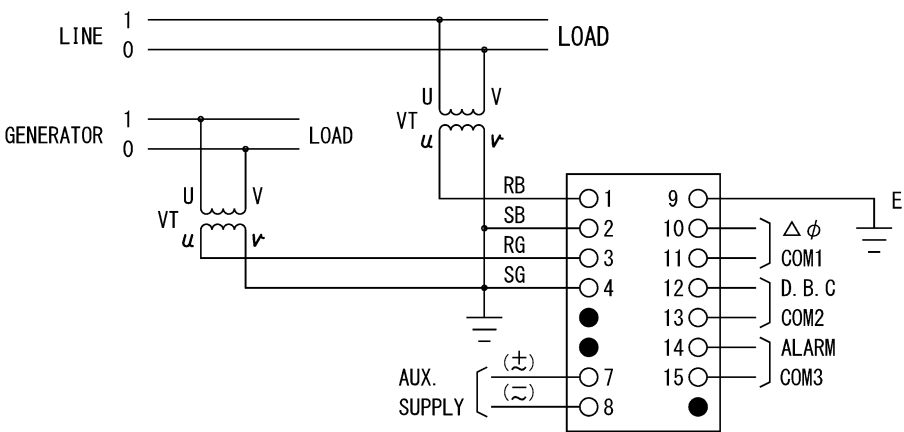

■ Precautions for wiring.

- Do not work with live wires.
- Check the wiring diagram before wiring.
- Use crimp terminals and tools that match the amount of electricity and terminal size for wiring.
- Tighten the terminal screw with a tool and tightening torque suitable for the screw size.  
 Recommended tightening torque, M3 screw : 0.5 to 0.6N·m, M4 screw : 1.0 to 1.3N·m,  
 M5 screw : 2.0 to 2.5N·m
- Attach the terminal cover after wiring.
- When connecting directly to the main power supply, install an appropriate fuse externally.
- Be sure to ground the ground terminal E (terminal 9) to improve the shielding effect.
- Separate the wiring on the strong current side and the wiring on the weak current side, and take measures against noise.



4.5 Operating precautions

(1) Notes on input/output signals.

- ① The input/output terminals are covered. Attach the cover after wiring. Also, do not touch the terminals while the power is on.
- ② The switching capacity of the control output (optical MOS-FET relay) is 100V DC and 100mA. Attach an element to the coil of the relay used externally of this product to absorb the back electromotive force generated when the product is opened or closed.

(2) Precautions when starting an operation

Apply auxiliary power after the voltage is established (85 to 127V AC, 88 to 143V DC). If the voltage rises slowly, malfunction may occur in the unstable power supply area.

(3) Precautions during operation.

- ① Settings cannot be changed during operation. When changing the settings, set all the auxiliary supply, bus input and generator input to no voltage.
- ② Do not touch the device while it is in operation.

(4) Precautions after completion of synchronization check.

After the synchronization check is completed, as a general rule, the auxiliary supply, bus line input, and generator input are set to no voltage.

- <Caution> In the power-on state, the operation is as follows.
- Dead bus detection operates when only auxiliary power is applied.
  - Dead bus detection operates when auxiliary supply and bus line input or generator input are applied.
  - When the auxiliary supply, bus input, and generator input are applied and the conditions are met, the synchronization check signal turns ON.

4.6 How to set up

Please refer to the setting values below and change the settings before applying power. If a setting change is made after power is applied, control will stop and an alarm is output. When resetting the alarm, please set the power supply to no voltage.

(Arrangement of setting device)

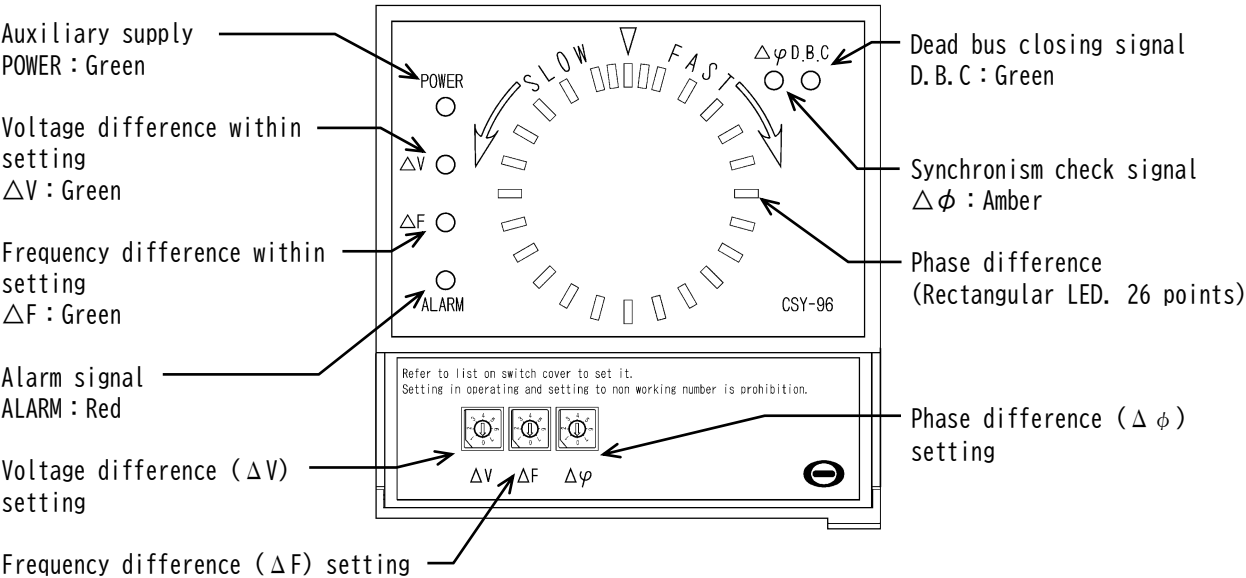

(Step of setting)

(1) Voltage difference ( $\Delta V$ ) setting (Rotary code switch)

Refer to the table below and set the voltage difference ( $\Delta V$ ) setting rotary code switch to the desired value. If code 4 to 7 or 0 is set, control stops, and an alarm is output.

Code	Voltage difference setting value ( $\Delta V$ )
1	3%
2	5%
3	10%
4	—
5	—
6	—
7	—
0	—

← Default setting 5%

For AC input 110V AC : 110V AC=100%  
For AC input 110/ $\sqrt{3}$ V AC : 110/ $\sqrt{3}$ V AC=100%

(2) Frequency difference ( $\Delta F$ ) setting (Rotary code switch)

Refer to the table below and set the frequency difference ( $\Delta F$ ) setting rotary code switch to the desired value. If code 7 or 0 is set, control stops, and an alarm is output.

Code	Frequency difference setting value ( $\Delta F$ )
1	0.05Hz
2	0.1 Hz
3	0.15Hz
4	0.2 Hz
5	0.25Hz
6	0.3 Hz
7	—
0	—

← Default setting 0.1Hz

(3) Phase difference ( $\Delta \phi$ ) setting (Rotary code switch)

Refer to the table below and set the phase difference ( $\Delta \phi$ ) setting rotary code switch to the desired value.

Code	Phase difference setting value ( $\Delta \phi$ )
1	3°
2	5°
3	10°
4	15°
5	20°
6	25°
7	30°
0	35°

← Default setting 15°

<Note> Reference ; Relationship of  $\Delta \phi$ ,  $\Delta F$  set point and  $\Delta \phi$  output ON time.

Phase difference $\Delta \phi$ setting point	$\Delta \phi$ output ON time ( $\pm \Delta \phi$ ) [ms]					
	$\Delta F=0.05\text{Hz}$	$\Delta F=0.1\text{Hz}$	$\Delta F=0.15\text{Hz}$	$\Delta F=0.2\text{Hz}$	$\Delta F=0.25\text{Hz}$	$\Delta F=0.3\text{Hz}$
3°	333	167	111	83	67	56
5°	556	278	185	139	111	93
10°	1111	556	370	278	222	185
15°	1667	833	556	417	333	278
20°	2222	1111	741	556	444	370
25°	2778	1389	926	694	556	463
30°	3333	1667	1111	833	667	556
35°	3889	1944	1296	972	778	648

4.7 Setting example

4.7.1 Setting items

- ① Voltage difference ( $\Delta V$ )
- ② Frequency difference ( $\Delta F$ )
- ③ Phase difference ( $\Delta \phi$ )

Setting example

Setting item	Default	Example of setting
Voltage difference ( $\Delta V$ )	5%	5%
Frequency difference ( $\Delta F$ )	0.1Hz	0.1Hz
Phase difference ( $\Delta \phi$ )	15°	15°

4.7.2 Judgment of set value

- ★① Voltage difference (Suppose the bus voltage 6600V and  $\Delta V = 5\%$ )  
 Detects within  $\pm 5\% = \pm 330V$  (6270 to 6930V) for bus voltage of 6600V.
- ★② Frequency difference (Suppose the bus frequency 50Hz and  $\Delta F = 0.1Hz$ .)  
 Detects within  $\pm 0.1Hz = 50Hz \pm 0.1Hz$  for bus frequency of 50Hz.
- ★③ Phase difference (Suppose the  $\Delta \phi = 15^\circ$ )  
 Output at synchronism point  $\pm 15^\circ$ .

5. Control function

5.1 Control range

- |  |  |
|--|--|
| (1) For AC input 110V AC<br>Bus voltage : 90 to 135V AC<br>Bus frequency : $50 \pm 3Hz, 60 \pm 3Hz$<br>Generator voltage : More than 80V<br>Frequency difference : Within $\pm 4Hz$<br>Output is stopped except for the above. | (2) For AC input $110/\sqrt{3}V$ AC<br>Bus voltage : 52 to 77V AC<br>Bus frequency : $50 \pm 3Hz, 60 \pm 3Hz$<br>Generator voltage : More than 47V<br>Frequency difference : Within $\pm 4Hz$<br>Output is stopped except for the above. |
|--|--|

5.2 Control output and description

- (1) Display of frequency difference within setting ( $\Delta F$ ).  
 If a frequency difference are within the range of  $\Delta F$  setting value, LED lights of  $\Delta F$ .  
 Hysteresis 0.03Hz (In case of  $\Delta F=0.1Hz$ , LED lights within 0.1Hz)  
 Return (LED lights on  $\rightarrow$  LED lights off) : Over  $\Delta F+0.03Hz$  (In case of  $\Delta F=0.1Hz$ . LED lights off at 0.13Hz)
- (2) Display of voltage difference within setting ( $\Delta V$ ).  
 If a voltage difference are within the range of  $\Delta V$  setting value, LED lights of  $\Delta V$ .  
 Hysteresis 0.5% (In case of  $\Delta V=5\%$ , LED lights within 4.5%)  
 Return (LED lights on  $\rightarrow$  LED lights out) : Over 5.0%

- (3) Synchronism check signal ( $\Delta \phi$ ).  
 If the voltage difference and frequency difference for the bus voltage and the generator voltage is within the set value and the phase difference is within  $\pm \Delta \phi$ , the normally open contact (a-contact) signal is output and the LED lights.

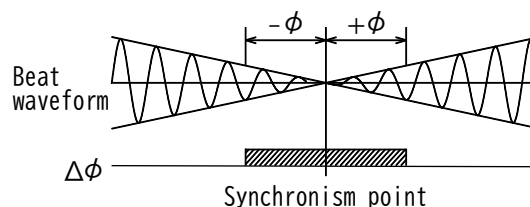

- (4) Dead bus closing signal (D.B.C)  
 When the voltage of bus voltage (VB) or generator voltage (VG) will be 47% or less of the rated voltage, normally open contact (a contact) signal is output and lights the LED.  
 A return becomes more than 50%.

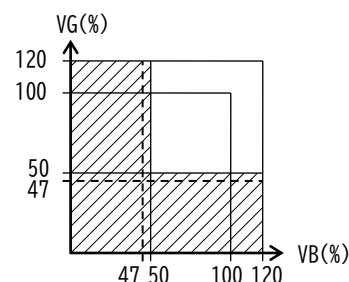

- (5) Alarm signal (ALARM)  
 Equipment error (ROM, RAM, A/D error, other) or setting error output normally open contact (a contact) signal at occurrence, and LED lights.

## 6. Operation overview

(1) Before application of auxiliary supply [bus voltage (VB) and generator voltage (VG) are no voltage].

- ① When checking the wiring to this product, make sure that all auxiliary supply and signal lines are in a no-voltage state. In either case, the input is LINE side : bus line (receiving) voltage, GENERATOR side : generator voltage.
- ② Change each set value (see 4.6 on page 8) before applying auxiliary supply.  
Changes to the set value after auxiliary supply is applied will not be accepted, control will stop and an alarm (ALARM) will be output.

(2) Auxiliary supply applied [bus voltage (VB) and generator voltage (VG) are no voltage].

When auxiliary supply is applied to this product, dead bus detection operates (D.B.C output ON, D.B.C LED lights) about 3 seconds later.  $\Delta V$ ,  $\Delta F$ , and  $\Delta\phi$  do not operate.

The same applies when either or both of the bus voltage and generator voltage are 47% or less of the rated voltage.

(3) Auxiliary supply, bus voltage (VB) and generator voltage (VG) applied.

When the bus voltage (VB) is 90 to 135 VAC (52 to 77 VAC for  $110/\sqrt{3}$  VAC AC input), the generator voltage (VG) is 80 VAC or higher (47 VAC or higher for  $110/\sqrt{3}$  VAC AC input), and the voltage difference  $\Delta V$  and frequency difference  $\Delta F$  are within the set values, the synchronization check signal ( $\Delta\phi$ ) is output within the phase difference  $\pm\Delta\phi$ , the LED ( $\Delta\phi$ ) lights up.

$\Delta\phi$  is not output unless all the conditions for voltage range, frequency range (Bus frequency [FB] is within 50Hz or 60Hz $\pm$ 3Hz) and  $\Delta V$  and  $\Delta F$  are met.

About  $\Delta\phi$  detection

- When the bus voltage and generator voltage are applied (same voltage, same frequency, same phase) after the auxiliary supply has been applied for approximately 3 seconds,  $\Delta\phi$  is detected in approximately 0.2 seconds (Including voltage difference detection, frequency difference detection, and phase difference detection).  
If D.B.C is being output, turn off the D.B.C output and  $\Delta\phi$  is output.
- Detection time is approximately 3 seconds (including voltage difference detection, frequency difference detection, and phase difference detection) when auxiliary supply, bus voltage, and generator voltage are applied.  
In this case, D.B.C is not detected, but  $\Delta\phi$  is detected.

(4) After completion of synchronism check.

After the synchronization check is completed, as a general rule, the power supply input, bus line input, and generator input are set to no voltage.

<Caution> In case of auxiliary supply and input applied state, the operation will be as follows.

- Dead bus detection operates when only auxiliary power is applied.
- When auxiliary supply and bus line input or generator input is applied, dead bus detection operates.
- When the auxiliary supply, bus line input and generator input are applied, the synchronization check signal will be ON if the conditions are met.

7. Test

Please refer to the following when conducting a mock test.

1) Performance test

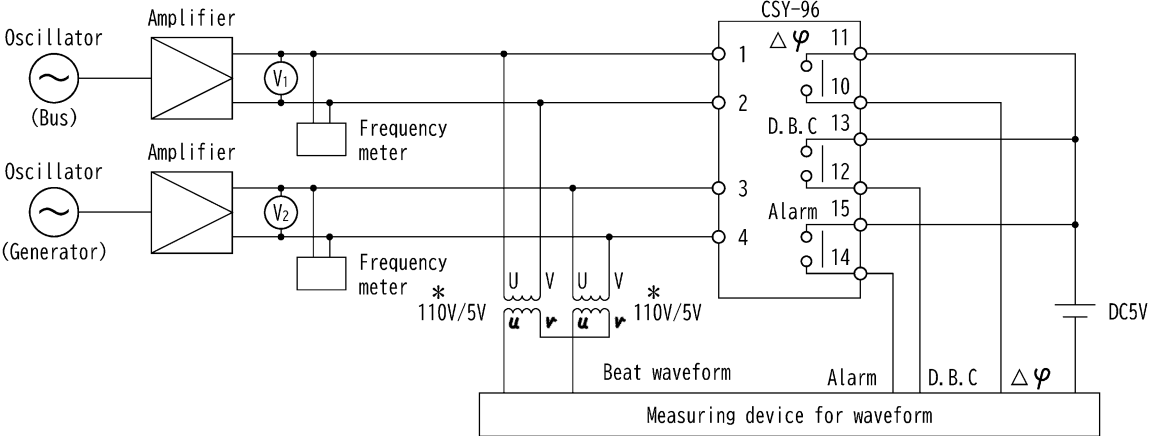

\* When AC input AC110/√3V specification is used, it is “AC110/√3V/5V” .

- ① Apply auxiliary supply and verify that the "POWER" LED is illuminated.
- ② Apply voltage to the bus input (terminals 1-2) and the generator input (terminals 3-4). When the voltage difference and frequency difference are less than the set values (ΔF LED ON, ΔV LED ON) and within Δφ, confirm that Δφ (normally open contact [a contact]) is output and the LED lights.
- ③ When the bus voltage (VB) or generator voltage (VG) is 47% or less of the rated voltage, confirm that the D.B.C (normally open contact [a contact]) outputs and the LED lights. The same applies when both the bus voltage (VB) and generator voltage (VG) are 47% or less of the rated voltage. A return becomes more than 50%.

8. Specification and performance

8.1 Specification

Item		Specification
AC input	Bus side input (Single-phase)	110V AC 50/60Hz 0.5VA or
	Generator side input (Single-phase)	110/√3V AC 50/60Hz 0.5VA
Control output	Synchronism check signal (Δφ)	Optical MOS-FET relay output MAX. 100V DC, 100mA
	Dead bus closing signal (D.B.C)	
	Alarm signal (ALARM)	
Auxiliary supply		100/110V AC 50/60Hz (85 to 127V AC) 5VA 100/110V DC (88 to 143V DC) 5W AC/DC power supply
Display	POWER	Green LED
	Synchronism check signal (Δφ)	Amber LED
	Dead bus closing signal (D.B.C)	Green LED
	Voltage difference within setting (ΔV)	Green LED
	Frequency difference within setting (ΔF)	Green LED
Measurement display	Alarm signal (ALARM)	Red LED
	Phase difference	Rectangular LED : Amber LED and Green LED (Green LED is synchronism point only) Total 26 points. 15° interval, 24 points. And 7.5° interval, 2 points (Back and forth a synchronism point).
Other	Setting	Rotary code switch ×3

## 8.2 Performance

Item		Specification	
Accuracy	Voltage difference	$\pm 1.0\%$	
	Frequency difference	$\pm 0.03\text{Hz}$	
	Measurement phase difference	$\Delta F \leq 0.10\text{Hz} : \pm 1^\circ$ $0.10 < \Delta F \leq 0.20\text{Hz} : \pm 2^\circ$ $0.20 < \Delta F \leq 0.30\text{Hz} : \pm 3^\circ$	
Characteristic	Influence of temperature	Within accuracy by $23 \pm 20^\circ\text{C}$ .	
	Influence of frequency	Within accuracy by $\pm 3\text{Hz}$ for bus rated frequency.	
	Influence of voltage	Within accuracy by 90 to 135V AC (For AC input 110V AC) Within accuracy by 52 to 77V AC (For AC input $110/\sqrt{3}\text{V AC}$ )	
	Influence of auxiliary supply	AC power supply	Within accuracy by 85 to 127V AC.
		DC power supply	Within accuracy by 88 to 143V DC.
Compliance standards	Complied to JIS C 1111 : 1989		
Strength	Overvoltage strength	AC input	1.5 times 10 seconds of rated voltage, and 135V continuation. (For AC input 110V AC) 1.5 times 10 seconds of rated voltage, and 77V continuation. (For AC input $110/\sqrt{3}\text{V AC}$ )
		Aux. supply	1.5 times 10 seconds of 100/110V AC, and 127V AC continuation. 1.5 times 10 seconds of 100/110V DC, and 143V DC continuation.
	Insulation resistance	Between electric circuit and case (ground).	Above $30\text{M}\Omega$ with 500V DC
		Between AC input and auxiliary supply and control output.	
	Withstand voltage	Between electric circuit and case (ground).	2000V AC (50/60Hz) 1 minute
		Between AC input and auxiliary supply and control output.	
	Impulse withstand voltage	Between electric circuit and case (ground).	5kV, $1.2/50\mu\text{s}$ Both positive and negative polarity, for 3 times each.
	Shock	Acceleration $294\text{m/s}^2$ . 3 times in each of the X, Y and Z directions.	
Vibration	Frequency 16.7Hz, Double amplitude 1mm. 10 minutes in each of the X, Y and Z directions.		
Operating temperature and humidity limits		0 to $55^\circ\text{C}$ , 5 to 95% RH (Non condensing)	
Storage temperature limits		$-10$ to $+70^\circ\text{C}$	
Case color		Black (Munsell N1.5)	
Mass		Less than 1kg	

## 9. Principle of operation

### 9.1 Block-diagram

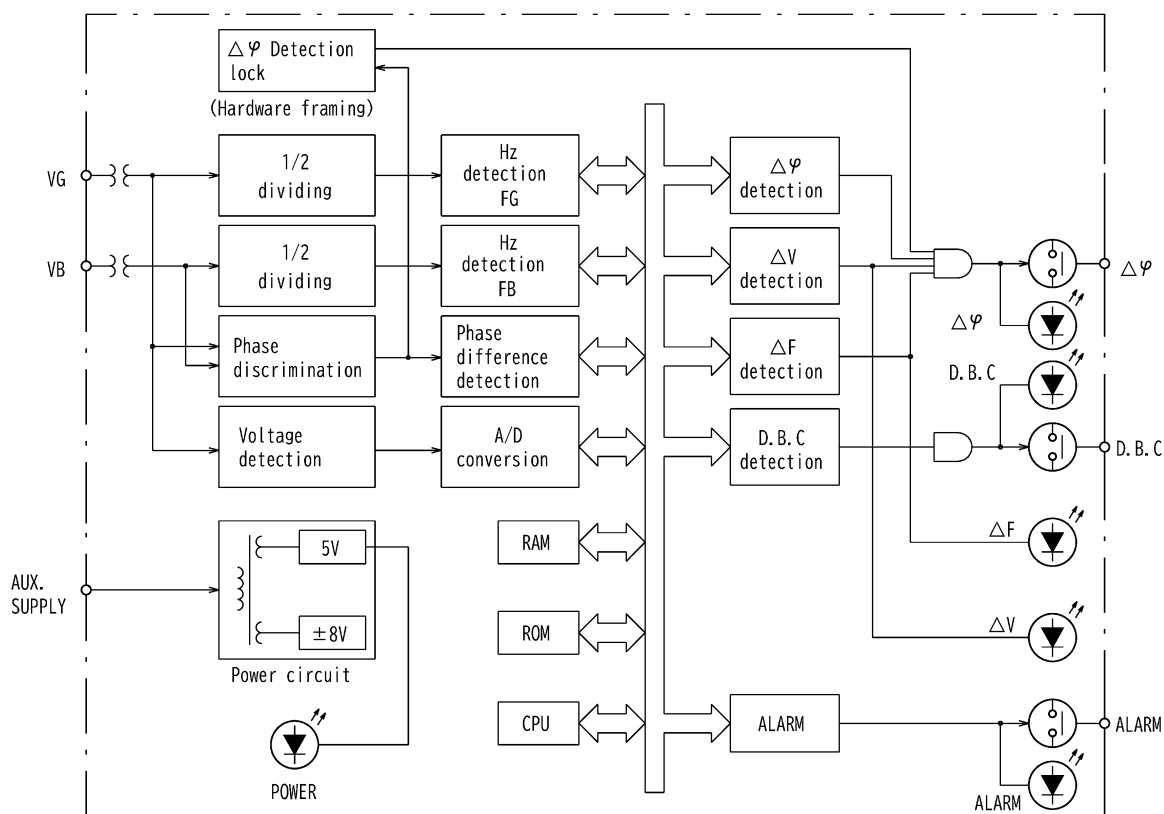

### 9.2 Explanation of operation

#### (1) Frequency measurement

The bus voltage (VB) input and the generator voltage (VG) input are isolated by a VT, then input to the frequency detection circuit via a waveform shaping circuit and a frequency dividing circuit. In the frequency detection circuit, the cycle of AC is counted, taken in the data bus, and the frequency is calculated by software calculation (1 / cycle). When the frequency difference is within the set value ( $\pm\Delta F$ ), the LED of  $\Delta F$  (within set value) will light.

#### (2) Voltage measurement

The bus voltage (VB) input and the generator voltage (VG) input are isolated by a VT and then input to the voltage detection circuit. In the voltage detection circuit, measure the effective value of the AC voltage and load it on the data bus after A/D conversion. When the voltage difference is within the set value ( $\pm\Delta V$ ), the LED of  $\Delta V$  (within set value) will light.

#### (3) Phase measurement

$\Delta\phi$  output counts the pulse width measured by the phase discrimination circuit, captures it on the data bus, and calculates the phase difference from the synchronization point by soft calculation. When the frequency difference ( $\Delta F$ ) and the voltage difference ( $\Delta V$ ) are within the set value and the phase difference is within  $\Delta\phi$ , the synchronization check signal ( $\Delta\phi$ ) is output. At the same time,  $\Delta\phi$  LED lights.

#### (4) $\Delta\phi$ detection lock

This circuit consists of hardware, while  $\Delta\phi$  is software. A phase difference larger than the  $\Delta\phi$  set value is detected, AND with the  $\Delta\phi$  output detected by software to perform fail-safe of the  $\Delta\phi$  output.

#### (5) D.B.C detection

When either or both of the bus voltage (VB) and generator voltage (VG) measured by the voltage measurement circuit are 47% or less of the rated voltage, the D.B.C (normally open contact [a contact]) outputs and the LED lights. A return becomes more than 50%.

#### (6) Auxiliary supply

The power supply of this product supplies it from the auxiliary supply terminal. After isolation with VT, the voltage is stabilized to 5V,  $\pm 8V$  and supplied to the circuit.

## 10. Maintenance

## 10.1 Error description

No.	Contents of error	Control status	Fault output	Reset condition	Note
1	ROM/RAM error	Control stop	Alarm output		Equipment replacement
2	A/D error	Control stop	Alarm output		Equipment replacement
3	Setting error	Control stop	Alarm output	Setting change or auxiliary power OFF	
4	Bus voltage out of range	Control stop		Automatic recovery	D. B. C operation excluded
5	Generator voltage out of range	Control stop		Automatic recovery	
6	Bus frequency out of range	Control stop		Automatic recovery	
7	Generator frequency out of range	Control stop		Automatic recovery	

## 10.2 Troubleshooting

No.	Details of the abnormality	Probable cause	Countermeasure method
1	POWER LED does not lights	Auxiliary power is not applied	Check the auxiliary power supply
		Equipment fault	Equipment replacement
2	$\Delta V$ LED does not lights	Voltage not balanced	Check the voltage difference
		If voltage is balanced, equipment fault	Equipment replacement
3	$\Delta F$ LED does not lights	Frequency not balanced	Check the frequency difference
		If frequency is balanced, equipment fault	Equipment replacement
4	D. B. C signal not output. (D. B. C LED is not lights)	Voltage conditions are not aligned	Check the voltage conditions (VB or $V_G \leq 47\%$ )
		If voltage conditions are met, equipment failure	Equipment replacement
5	Synchronism check signal does not output. ( $\Delta\phi$ LED is not lights)	$\Delta V$ and $\Delta F$ are not within the specified values	Check the $\Delta V$ , $\Delta F$
		Equipment fault	Equipment replacement
6	Alarm is output	Input error of setting value	Check the setting value
		ROM error, RAM error, A/D error	Equipment replacement

**DAIICHI ELECTRONICS CO., LTD.**

Tokyo Office : 11-13, Hitotsuya 1-chome, Adachi-ku, Tokyo, 121-8639, JAPAN.  
TEL : +81-3-3885-2411 , FAX : +81-3-3858-3966

Kyoto Office : 1-19, Ichinobe-Nishikawahara, Jyoyou-shi, Kyoto, 610-0114, JAPAN.  
TEL : +81-774-55-1391 , FAX : +81-774-54-1353

Revision J, DATE : November 26, 2024