

INSTRUCTION MANUAL

ANALOG INPUT COMMUNICATION UNIT

FCTT

(INPUT 2 CIRCUITS)

Thank you for purchase DAIICHI ELECTRONICS product.
Please this instruction manual carefully before use.

Safety precautions

■ Usage environment and product conditions

Please be sure to use this product in a place that meets the following conditions.

In places that do not meet this condition, it may cause malfunction or failure and product life decline.

- Within the range of ambient temperature -10 to $+55$ °C, humidity 5 to 90% RH.
- Place free of dust, corrosive gas, salt and oily smoke. (Corrosive gas : SO_2 / H_2S , etc.)
- Location that is not affected by vibration and shock.
- Location that is not affected by external noise.
- Altitude 1000m or less.

■ Outdoor use conditions

- These products are not a dustproof, waterproof, and splash proof construction.
Please avoid the place with much dust. Please do not install in the place directly exposed to the rain and water droplets.
- Please do not install in the place directly exposed to the sun even through the glass.
Discoloration and degradation of a name plate, and deformation of the box by the surface temperature rise may caused.

■ Mounting and wiring

Please refer to this instruction manual for mounting and the wiring.



- Please refer to connection diagram for the wiring.
- Hot line work is prohibited.
- Please use an electrical wire size suitable with the rated current.
- Please check the tightening of the screw.

■ Maintenance and inspection

- Please confirm that RUN LED is lit.
- Inspection during energization is dangerous.
- No replacement in periodic inspection.
- In case you check an output unavoidably by the hot line condition, please warn to be unable to touch output wiring and a human body to an input and an auxiliary power terminal.
- After wiring change and maintenance, attach the terminal cover (option).
- Please wipe off lightly with the dry soft cloth. Please do not use the organic solvent, chemicals, cleaners, etc., such as an alcohol, for cleaning.

■ Storage

Please be storage in a place that meets the following conditions.

- The ambient temperature is within -20 to $+70$ °C (storage temperature).
- Daily average temperature 40 °C or less.
- Location corresponding to the usage environment and use conditions.
- Aluminum electrolytic capacitors are used for products. Please energize the power supply within one year after purchase.

■ Countermeasures against troubles

If this product breaks down within the warranty period, it will be repairs by DAIICHI ELECTRONICS.

■ Disposal

Please dispose of this product as industrial waste (noncombustible).
Mercury parts and a nickel-cadmium battery are not used for this product.

■ Warranty period.

The warranty period of the product is one year after the date of delivery.

Contents

Safety precautions	1
1. Outline on the product	3
1.1 Application	3
1.2 Features	3
2. Handling explanation	
2.1 Outline dimensions	3
2.2 Name and function	3
2.3 Cautions on mounting	4
2.4 Example of combination mounting	4
2.5 The mount to DIN rail, and the method of detachment	5
2.6 Connection	5
2.7 Handling explanation	6
3. Specification and performance	
3.1 Communication output specification	6
3.2 Auxiliary supply specification	6
3.3 Switch and display specification	7
3.4 Performance	7
3.5 Model name configuration and specification code	9
4. Troubleshooting	10

1. Outline on the product

This product is a plug-in type analog input communication unit that insulates DC voltage or DC current input 2 circuits and converts them into communication signals.

1.1 Application

Pressure gauge, flow meter, analog signal, such as temperature and humidity meter is used to monitor by RS-485 communication output (Modbus RTU).

1.2 Features

- The withstand voltage between input 1 and input 2 and communication output and auxiliary supply and cases is insulation of 1 minute for AC2000V (50/60Hz).
- Power supply applying status and communication status can be checked by LED. (LED color : Green)
- Conversion accuracy $\pm 0.2\%$ or less.
- Socket is standard attachment. Socket type : FW11

2. Handling explanation

2.1 Outline dimension

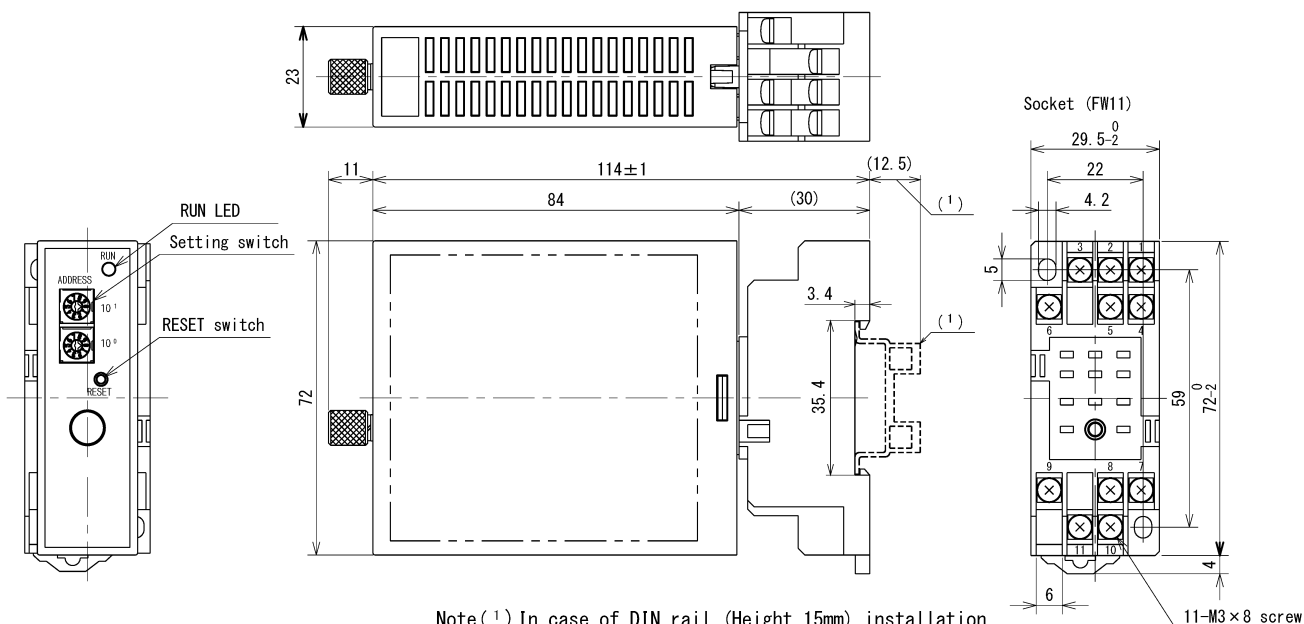

Note(1) In case of DIN rail (Height 15mm) installation.

Socket : Standard is M3×8 (dated washer) screw. M3×8 double washer type screw can support by designation, too. In designation of a M3×8 double washer type screw, please designate as socket type FW11-W at the case of an order.

2.2 Name and function

(1) RUN LED

The operation function of this product is indicated by LED (green).
The LED lights up at normally. When abnormal, it blinks in response to symptoms.
(For details, refer to 4.4 Switch and Display Specification)

(2) Setting switch

Set the communication address to be used for communication.
Set the communication address (1 to 89) separately with 10 digit switch and 1 digit switch.
This setting is read at power on. When setting is changed while power is being applied, the new address becomes valid by soft reset with the reset switch.

(3) Reset switch

This switch soft reset this product. Press it for 3 seconds or more to soft reset.

2.3 Cautions on mounting

The environmental conditions of installation space. Please select indoors without low mechanical vibration, dust, and corrosive gas.

There is no limit of a mounting position. A mounting instruction can select 35mm width DIN rail mounting and screw mounting. In screw mounting, please install with M3 screw or M4 screw. (However, the screw is not attached. The tightening torque of a screw, M3 : 0.45 to 0.60N·m, M4 : 1.00 to 1.30N·m)

The interval of FW11 and FW11 does not have designation.

Please consider radiation and wiring space and separate more than 100mm of the space above and below. (Reference of 2.4 section.)

Please secure the space distance of a terminal and a metal panel 10mm or more.

2.4 Example of combination mounting (Unit mm)

■ Screw installation

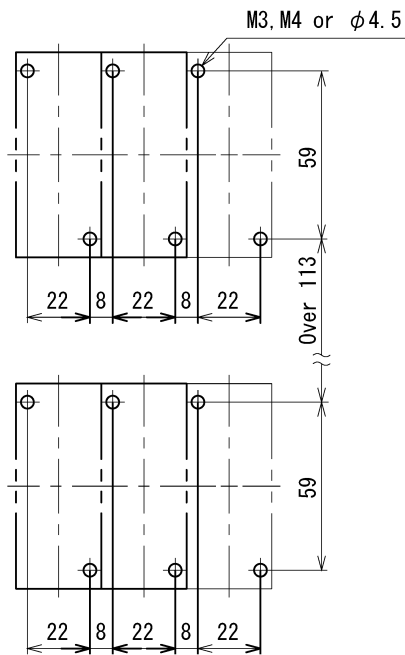

■ Rail installation

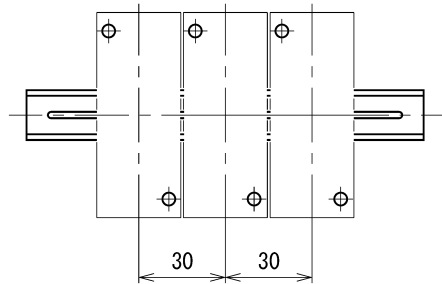

Please use rail of IEC, DIN technical standard 35mm width rail (strong type).

《 Recommendation product 》 Fuji Electric Co.,Ltd. TH35-15AL

2.5 The mount to DIN rail, and the method of detachment.

<Cautions> If it insert and remove the body section from a socket, please carry out after shutting down a power supply and an input signal.

(1) How to fix a socket.

Set the base socket so that its slider is at the bottom. Position the upper hook at the rear side of base socket on the DIN rail and push in the lower.

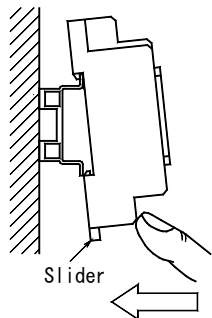

(2) How to fix a body to a socket.

Do in the direction which can read a label character correctly, and insert a body straightly. Press with the screw of a body. (Please do not tighten a screw too much.)

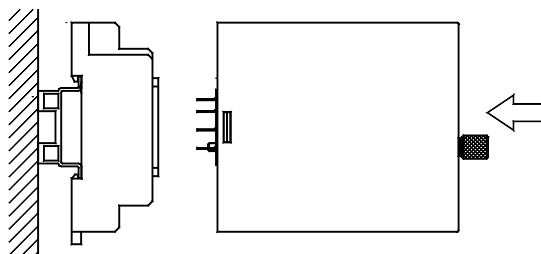

(3) How to remove a body from a socket.

Loosens the screw of a body. Please pull a body to straight near side.

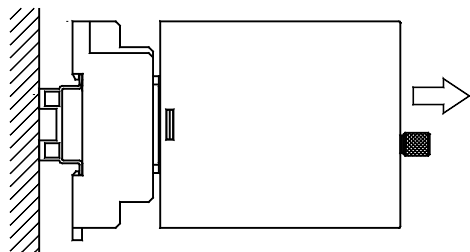

(4) How to remove a socket.

Push down the slider utilizing a minus screwdriver and pull.

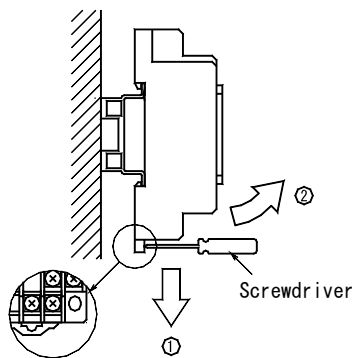

< Cautions >

If a body is taken out and inserted aslant, the terminal of a body will bend and a loose connection etc. will occur.

2.6 Connection

Socket (FW11)

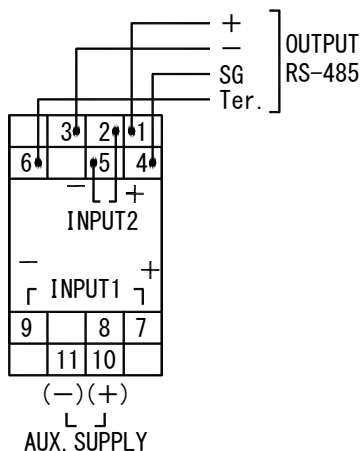

By short-circuiting Ter. and -, a terminating resistor of 100Ω is connected.

If guidance induced lightning surge may occur on the input side / output side or auxiliary power supply side, install line surge protector and arrester etc. between the line and ground to protect this product.

2.7 Handling explanation

In dealing with this product, please carry out the always right handling with careful attention to the following way.

- (1) Please check whether the voltage and the input signal of a supply power supply have agreed with the specification of this product before applying a power supply.
- (2) Make sure that the wiring is connected to the specified terminal position (indicated on the nameplate).
- (3) Please close lock screw when they installed main frame in socket.
- (4) Please keep away wiring from noise source.
- (5) A rush current flows at the case of a power-on. Please be careful of overcurrent protection of the power supply to be used etc.

AC110V : Peak about 1.7A, Time constant about 1.8ms

AC220V : Peak about 3.3A, Time constant about 1.8ms

DC110V : Peak about 1.2A, Time constant about 1.8ms

DC220V : Peak about 2.4A, Time constant about 1.8ms

3. Specification and performance

3.1 Communication output specification

Item	Specification
Standard	TIA-485-A (2003)
Communication system	Half-duplex two-wire system
Synchronous system	Asynchronous communication method.
Bit rate	9600bps / 19200bps / 38400bps (Designation at order)
Transmission code	NRZ
Start bit	1 bit
Data bit	8 bit
Parity	Nothing / Odd number / Even number (Designation at order)
Stop bit	1 bit
Error detection	CRC-16 ($X^{16} + X^{15} + X^2 + 1$)
Connection method	Connection by M3 screw (FW11 socket)
Cable length	1000m (Max.)
Address ⁽¹⁾	01 to 89 (01H to 59H) and 00 (Communication unused)
Number of connection	Max. 64 ⁽²⁾ / system
Transmission character	Binary
Termination resistor	100Ω, Connected to transmission line by short circuit of minus terminal and Ter. terminal.

Note⁽¹⁾ If the address is set to 00 and 90 to 99, no communication will be made. (Communication not used)

Note⁽²⁾ When connecting a device (with device of 32 connections), even one unit will be the number of connections for two units. Therefore, the maximum number of connected units is reduced.

3.2 Auxiliary supply specification

Item	Specification
Auxiliary supply range and consumption VA	AC80 to 264V 50/60Hz (Rated voltage AC100/110V 3.5VA , AC200/220V 5.0VA) DC80 to 264V (Rated voltage DC100/110V 3.0W , DC200/220V 3.0W) AC-DC dual-use
Inrush current (Time constant)	Rated voltage AC110V 50/60Hz 1.7A or less (About 1.8ms)
	Rated voltage AC220V 50/60Hz 3.3A or less (About 1.8ms)
	Rated voltage DC110V 1.2A or less (About 1.8ms)
	Rated voltage DC220V 2.4A or less (About 1.8ms)
Fuse	Rated current 160mA (At designation with fuse)

3.3 Switch and display specification

Item	Specification	
Setting switch (10 ¹ , 10 ⁰)	Rotary code switch (2 digits)	
	Address setting range : 1 to 89 (10 digits or 1 digit, set individually) Factory setting is 00 (communication not used)	
Reset switch	Pressing the switch for 3 seconds or longer will soft reset.	
RUN LED	Always on	Normal operation
	Blinking at 1 second cycle (0.5 seconds on, 0.5 seconds off)	Time out, Communication error, CRC error
	Blinking at 2 second cycle (1 second on, 1 second off)	Setting error (Change communication address while applying power)

3.4 Performance

Item	Condition and tolerance limit	
Conversion accuracy	$\pm 0.2\%$ (% for span)	
Influence of self-heating	$\pm 0.2\%$ (% for span)	The difference of the output value of immediately after operation (after 1 to 3 minutes) and after 30 to 35 minutes.
Influence of temperature	$\pm 0.2\%$ (% for span)	The difference of the output value when changing $23 \pm 10^\circ\text{C}$.
Influence of auxiliary supply	$\pm 0.1\%$ (% for span)	The difference of the output value when making supply voltage into the upper limit and lower limit of the variation range, and the output value in rated voltage.
Response time of input circuit	0.1 second or less (The time until the output of the input filter amplifier circuit reaches 90% of the final stationary value)	
Insulation resistance	Between electric circuit and case.	DC500V More than 50M Ω
	Between input and communication output and auxiliary supply.	
	Between input circuits.	
Withstand voltage	Between electric circuit and case.	AC2000V (50/60Hz) 1 minute There is no electrical damage or mechanical damage.
	Between input and communication output and auxiliary supply.	
	Between input circuits.	
Overload capacity	Current input	There is no electrical damage. When returning to the standard test state, satisfy conversion accuracy.
	Voltage input	
	Auxiliary supply	
Impulse withstand voltage	Between electric circuit (except communication output) and case. 5kV 1.2/50 μs Both positive and negative polarity, for each 3 times.	There is no electrical damage or mechanical damage. When returning to the standard test state, satisfy conversion accuracy.
	Between input terminal and communication output terminal. 3kV 1.2/50 μs Both positive and negative polarity, for each 3 times.	
Vibration	Single amplitude : 0.15mm 10 to 55 to 10Hz Sweep 5 times with 1 octave per minute. There is no mechanical damage. When returning to the standard test condition, the percentage of the difference between the output values before and after the test relative to the base value is within 100% of the class index.	

Item	Condition and tolerance limit	
Shock	294m/s ² , X-Y-Z direction in the forward and reverse each 3 times.	There is no mechanical damage. When returning to the standard test condition, the percentage of the difference between the output values before and after the test relative to the base value is within 100% of the class index.
Damped oscillatory wave immunity test	<ul style="list-style-type: none"> • 1 to 1.5MHz, 1/2 decay time 6μs or more • Repetition frequency 50 times or more / s, 3 times with an applied time of 30 seconds • Peak voltage : 2kV • Input (Common), Auxiliary supply (Normal / Common) • Applied time and peak voltage are specified by company standard value 	Output fluctuation within 10%, and not malfunctioning. And, malfunction and communication stop must not occur.
Square impulse immunity test	<ul style="list-style-type: none"> • Pulse width : 1μs and 100ns • Repetition period : 20ms or more, Applied voltage : \pm1kV • Rise time of pulse : 1ns \pm30% • Input (Common), Communication output (Inductive and capacitive coupling), Auxiliary supply (Normal / Common) • Pulse width 1 μs and repetition cycle are specified by company standard value. 	Output fluctuation within 10%, and not malfunctioning. And, malfunction and communication stop must not occur.
Radio wave immunity test	<ul style="list-style-type: none"> • Transceiver output : 144MHz, 430MHz • Field strength : 10V/m • Direction of irradiation : X,Y,Z 	Output fluctuation within 10%, and not malfunctioning. And, malfunction and communication stop must not occur.
Electrostatic discharge immunity test	Contact discharge \pm 4kV (charging voltage) Test level 2	After the test, the output change 0.2%
	Air discharge \pm 8kV (charging voltage) Test level 3	After the test, that there is no damage
Socket terminal screw	M3 \times 8 washer screw (FW11 socket)	
Material	FCTT : Flame retardant ABS resin (V-0) , FW11 socket : Flame retardant PPO resin (V-1)	
Color	Black (Munsell N1.5)	
Mass	Main body : Approx. 130g , Socket : Approx. 50g	
Accessory	FW11 socket, 1	
Operating temperature and humidity limits	-10 to +55 $^{\circ}$ C , 5 to 90% RH (Non condensing)	
Storage temperature limits	-20 to +70 $^{\circ}$ C	
Protection rating	IP30	
Altitude	1000m or less	

3.5 Model name configuration and specification code (Designation at ordering)

TYPE Specification code
FCTT — ① ② ③ ④ ⑤ **O**

- ① Input
- ② Output (Output specification, Communication protocol)
- ③ Bit rate, Parity
- ④ Auxiliary supply
- ⑤ Fuse for auxiliary supply

(Please refer to the following)

①	②	③	④	⑤
Input (Input resistance)	Output (Output specification, Communication protocol)	Bit rate, Parity	Auxiliary supply	Fuse for auxiliary supply
OA2 : DC0 to 50mV (About 1MΩ) OA3 : DC0 to 60mV (About 1MΩ) OA4 : DC0 to 100mV (About 1MΩ) OA5 : DC0 to 1V (About 1MΩ) OA6 : DC0 to 5V (About 1MΩ) OA7 : DC0 to 10V (About 1MΩ) OA8 : DC1 to 5V (About 1MΩ) OB2 : DC ±50mV (About 1MΩ) OB3 : DC ±60mV (About 1MΩ) OB4 : DC ±100mV (About 1MΩ) OB5 : DC ±1V (About 1MΩ) OB6 : DC ±5V (About 1MΩ) OB7 : DC ±10V (About 1MΩ) OC3 : DC0 to 1mA (About 100Ω) OC4 : DC0 to 5mA (About 100Ω) OC5 : DC0 to 10mA (About 100Ω) OC6 : DC0 to 16mA (About 100Ω) OC7 : DC4 to 20mA (About 100Ω) OD4 : DC ±1mA (About 100Ω) OD5 : DC ±5mA (About 100Ω) OD6 : DC ±10mA (About 100Ω) ZZZ : Other ⁽³⁾	M : RS-485 communication output (Modbus RTU)	0 : 9600bps, No parity 1 : 9600bps, Parity odd number 2 : 9600bps, Parity even number 3 : 19200bps, No parity 4 : 19200bps, Parity odd number 5 : 19200bps, Parity even number 6 : 38400bps, No parity 7 : 38400bps, Parity odd number 8 : 38400bps, Parity even number Z : Other ⁽³⁾	F : AC-DC80 to 264V (Rated voltage AC100/110V 50/60Hz AC200/220V 50/60Hz DC100/110V DC200/220V) (Expenditure VA in rated voltage AC110V : 3.5VA AC220V : 5.0VA DC110V : 3.0W DC220V : 3.0W)	1 : Without fuse 2 : Within fuse

Note⁽³⁾ Please consult other than the above.

4. Troubleshooting

Trouble	Probable cause	Handling
RUN LED is not lights	Auxiliary supply is not applied. (Wiring mistake, Auxiliary supply is low voltage)	Please by applying an auxiliary supply.
	Failure of equipment	Replacement of equipment
RUN LED is blinking (2 second cycle : 1 second on, 1 second off)	Changed the communication address while supplying auxiliary power	Please press RESET switch for more than 3 seconds.
RUN LED is blinking (1 second cycle : 0.5 seconds on, 0.5 seconds off)	Time out, Communication error or CRC error (Modbus) occurs	<ul style="list-style-type: none"> · Please check the CRC (Modbus) · Please refer to the "communication error occurs"
Communication error occurs	Communication cable is disconnected or not properly connected. (Polarity etc.)	Please check the communication cable
	The settings of this product and the host device do not match. (Bit rate, Data length, Parity, Stop bit)	Please check the communication setting
	Address duplication	

 **DAIICHI ELECTRONICS CO., LTD.**

Tokyo Office : 11-13, Hitotsuya 1-chome, Adachi-ku, Tokyo, 121-8639, JAPAN.
TEL : +81-3-3885-2411 , FAX : +81-3-3858-3966

Kyoto Office : 1-19, Ichinobe-Nishikawahara, Jyoyou-shi, Kyoto, 610-0114, JAPAN.
TEL : +81-774-55-1391 , FAX : +81-774-54-1353

Revision B, DATE : January 24, 2025