

INSTRUCTION MANUAL

ALARM SETTER
【Real scale type】

SD-H-105

SD-L-105

SD-HL-105

SD-HH-105

SD-LL-105

(With a contact delay circuit)

SD-H-105D

SD-L-105D

SD-HL-105D

SD-HH-105D

SD-LL-105D

Introduction

Thank you for your purchase of our product.

Read this instruction manual carefully before installation, wiring, and using this product.

Keep this instruction manual handy for reference at any time.

Have a contact with us or sales agent in case that this instruction manual is lost or damaged.

<Caution>

Have a contact with us when you have any questions or are aware of missing article.

Safety precaution

In the operation manual, the harm to a user or other persons and damage of property were prevented, and the important matter for using correctly safely is written in it.

Please read a text well after understanding the following contents (a display and a graphic symbol), and protect the mentioned item.

 **DANGER** Improper use may lead to death or severe injury.

 **WARNING** Improper use may possibly lead to death or severe injury.

 **ATTENTION** Improper use may lead to medium injury.

- We are not responsible for the damage caused by following condition (earthquake / fire which is not caused by us, action by third party, other accident, damage caused by our customer, misuse, product usage under abnormal condition).
- We are not responsible for secondary damage caused by product use / product malfunction(loss of profit, halt of business operation). We are also not responsible for damage caused by false operation in combination with connecting equipment which is beyond our control.

DANGER

- Do not disassemble, remodel and repair this product.
If judged as trouble, please contact our company or a distributing agent.
- Do not get this product wet to prevent generation of heat and ignition, product failure.
When this product gets wet, stop using it.
- Metal (wire etc.) other than wiring is not connected to the terminal (metallic portion) of this product.
- Do not work, if combustibles, and an inflammable medicine and inflammable gas are in the circumference.

WARNING

- Connect specified power supply.
Connecting power supply beyond specification causes fire and product failure.
- When dust has adhered to the terminal, remove dust after turning off the power.
- Follow the below-mentioned procedure when abnormality (fuming / bad odor) happens.
 - (1) Stop a power supply and input, and stop using.
 - (2) Contact our company or a distributing agent.

ATTENTION

- Do not use this product in a environment of high temperature / high humidity to prevent any damage.
- Do not touch the terminal during operation to prevent electric shock.
- Do not pull and bend connecting cable with force. Cable damage causes heat generation / burn and contact failure leads to equipment damage.
- Connection or inspection of apparatus are not performed by the wet hand.

Other precaution

- Don't mount or store this unit in the following environment.
 - Locations with excessive corrosive gas (SO₂ / H₂S / etc.)⁽¹⁾.
 - Locations with excessive dust.
 - Locations with excessive vibration or shocks.
 - Locations with excessive influence of external magnetic field ⁽²⁾.
 - Note⁽¹⁾ Corrosive gas : Sulfur dioxide SO₂, Hydrogen sulfide H₂S, etc.
 - Note⁽²⁾ Large current bus, saturable reactor, etc.
- Please wipe off lightly with the dry soft cloth.
 - When it wipes with the damp cloth or the dry cloth strongly, a surface is damaged. And, the character of a name plate may disappear.
 - Please do not use the organic solvent, chemicals, cleaners, etc., such as an alcohol, for cleaning.
- Mercury parts and a nickel-cadmium battery are not used for this product.
- Please dispose of this product as industrial waste (noncombustible).
- The precautions at the case of using by outdoor board.
 - ① These products are not a dustproof construction, waterproof construction, and splashproof construction. Please avoid the place with much dust. Moreover, please install in the place which requires neither rain nor waterdrop.
 - ② Please do not install in the place where sunlight hits directly. Discoloration and degradation of a name plate, and deformation of the box by the surface temperature rise may take place.

The warranty period and warranty scope.

Warranty period.

The warranty period of this product is for one year after supplying the appointed place.

Warranty scope

In the state of the normal use of product-specification within the range according to this instruction manual, the trouble within the warranty period performs exchange or repair gratuitously. However, the shipping expenses and the packing cost in the case of shipping obtain as payment on a customer. And, if it corresponds to the next, it does not warrant.

- (1) If it breaks down when converted or repaired except our company.
- (2) If it breaks down by use out of specification range.
- (3) If the cause of trouble is based on cause other than this product.
- (4) Transportation, movement, damage by falling, and trouble.
- (5) A natural disaster, disaster, etc., if it is the trouble which is irresponsible for a payment side (our company or distributing agent).

This warranty is a warranty of a product simplex. It cannot warrant the damage induced by trouble of this product.

Change of instruction manual written contents.

This instruction manual changes written contents without a notice by product improvement etc.

Content

1. Application	4
1.1 Features	4
1.2 Composition of type	4
2. Specification and performance	
2.1 Specification	5
2.2 Performance	5
2.3 Relay operation	6
2.4 Operation of an alarm output	7
3. Handling explanation	
3.1 Dimensions diagram	8
3.2 Cautions on mounting	8
3.3 Connection diagram	9
3.4 Cautions on connections	9
3.5 Cautions on installation	9
3.6 Setting	10
4. Principle of operation	
4.1 Block-diagram	10
4.2 Operating explanation	10
5. Inspection, and calibration and maintenance	
5.1 Receiving inspection	11
5.2 Periodic inspection	11
5.3 Maintenance	11
5.4 Trouble shooting	11
5.5 Check	11
5.6 Storage	12
5.7 Countermeasures against troubles	12

1. Application

This product is the alarm setter of small plug-in construction. This product outputs the excess and deficiency by the contact signal as compared with the value that had the input setting of DC voltage or DC current signal. Power, temperature, flow rate, pressure, liquid level, etc., you use it for each variables to be measured meter method broadly.

This product is with a contact delay function. A contact signal is not outputted to a momentary excess and deficiency input. A contact signal is outputted to an excess and deficiency input after constant time.

1.1 Features

- ① This is high-quality, is high reliability and is a product with a noise-proof design.
- ② The operation can be confirmed by an LED. (Non-detection : Green, Detection : Red)
- ③ This product can change the reach of the dead band.
- ④ This product is compact (plug-in type).
- ⑤ The contact delayed function can be added in an option.

1.2 Composition of type

TYPE
Specification number
 SD-(1)-105(2)-(3)(4)

(1) Setting system

Mark	Contents
H	High limit setting
L	Low limit setting
HL	High and low limit setting
HH	2 steps of high limit setting
LL	2 steps of low limit setting

(2) Option

Mark	Contents
Nothing	With no contact delay circuit
D	With a contact delay circuit

[Specification number]

(3) Input (Input resistance)		(4) Auxiliary supply (Variation range)	
A1	DC0 - 10mV (About 1MΩ)	C3	DC0 - 1mA (About 100Ω)
A2	DC0 - 50mV (About 1MΩ)	C5	DC0 - 10mA (About 100Ω)
A3	DC0 - 60mV (About 1MΩ)	C6	DC0 - 16mA (About 100Ω)
A4	DC0 - 100mV (About 1MΩ)	C7	DC4 - 20mA (About 100Ω)
A5	DC0 - 1V (About 1MΩ)	00	Other
A6	DC0 - 5V (About 1MΩ)		
A7	DC0 - 10V (About 1MΩ)		
A8	DC1 - 5V (About 1MΩ)		
		1	AC100V (±15%) 50/60Hz
		2	AC110V (±15%) 50/60Hz
		3	AC200V (±15%) 50/60Hz
		4	AC220V (±15%) 50/60Hz
		5	DC24V (±20%)
		6	DC48V (±20%)
		0	Other

2. Specification and performance

2.1 Specification

Item	Specification
Input	Reference to "Composition of type" Input production range, Voltage input : DC10mV to 250V Current input : DC1mA to 100mA
Auxiliary supply	Reference to "Composition of type"
Burden	AC : 3VA, DC : 3W
Contact composition	1c contact. Relay contact output.
Contact capacity	AC120V 1A ($\cos \phi = 1$), DC30V 2A (Resistance load)
Setting range	Minimum input value to maximum input value.
Dead band	0.5 to 5% variable (% for input span)
Starting delay	0.5 seconds (Standard) It's possible to make until 10 seconds.
Contact delay ⁽³⁾	2 seconds, 5 seconds, 10 seconds (Fixation) With a contact delay circuit.
Color	Black (Munsell N1.5)
Operating temperature and humidity limits	-10 to +55°C, 30 to 85% RH (Non condensing)
Storage temperature limits	-30 to +60°C
Mass	Approx. 450g

Note⁽³⁾ These specifications are specifications at the case of contact delay circuit (option) designation.

2.2 Performance

Item	Conditions	Tolerance limits		
Scale error	% for input span.	±3.0%		
Reproducibility of the operating point	% for input span.	±0.5%		
Operating time setting error ⁽⁴⁾	% for contact delay time.	±10 %		
Influence of temperature	% for input span. 23±10°C	Operating point	±0.2%	
		Contact delay ⁽⁴⁾	±5.0%	
Influence of auxiliary supply voltage	AC : ±15% of rated voltage. DC : ±20% of rated voltage.	Operating point	±1.0%	
		Contact delay ⁽⁴⁾	±5.0%	
Response time ⁽⁵⁾	90%→110% of an operation value.	Less than 0.3 seconds		
	110%→90% of an operation value.			
Overcurrent strength	10 times 5 seconds, 1.2 times continuation for rated current.	There is no damage		
Overvoltage strength	Input	Less than 100V : 2 times 10 seconds and 1.2 time continuation for rated voltage. Other : 250V continuation	There is no damage	
	Aux. supply			AC : 2 times 10 seconds and 1.2 times continuation for rated voltage. DC : 1.5 times 10 seconds and 1.2 times continuation for rated voltage.
Insulation resistance	Between electric circuits and case.	At DC500V	More than 50MΩ	
	Between input terminals and auxiliary supply terminals and output terminals.			
Withstand voltage	Between electric circuits and case	AC2000V (50/60Hz) 1 minutes	There is no damage	
	Between input terminals and auxiliary supply terminals and output terminals.	AC1500V (50/60Hz) 1 minutes		
Impulse withstand voltage	Between electric circuits and case.	4.5kV 1.2/50 μs Both positive and negative polarity each 3 times.	There is no damage	
Vibration	Vibration frequency 16.7Hz doubles amplitude 1mm. For each 10 minutes adds vibration to X, Y, Z side.		There is no damage	
Shock	Duration : For each 2 times adds shock of 294m/s ² (30G) to X, Y, Z side. Malfunction : 98m/s ² (10G)		There is no damage	

Note⁽⁴⁾ These specifications are specifications at the case of contact delay circuit (option) designation.

Note⁽⁵⁾ This is performance when there is not an option.

- About transition of a contact.

In DC load switching, transition of a contact may start and a contact may not return by uneven connection. A contact evaporates locally with arc heat, what did contact evaporation adheres and deposits this on minus pole from + pole, and a single-sided convex and opposite side serves as a concave.

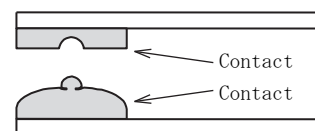

〈Measure〉 Please be sure to use each relay within a rated load.

2.3 Relay operation

- Contact delay function.

Relay operation in over-input detection.

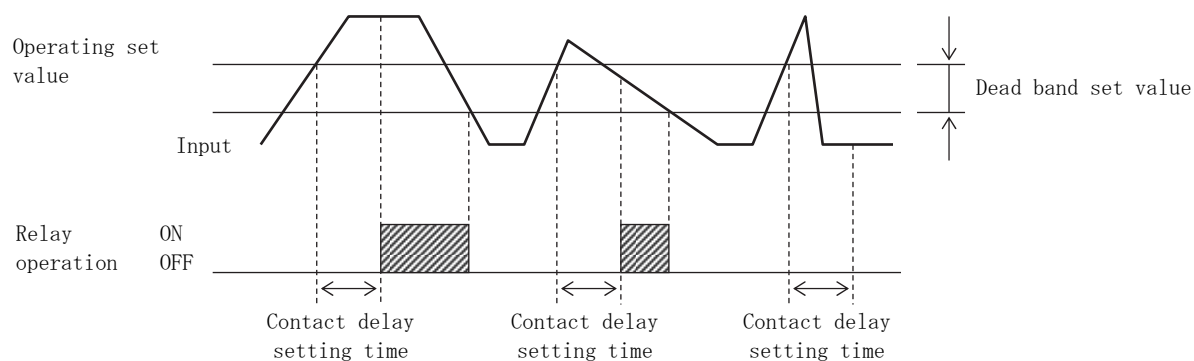

Relay operation in shortage input detection.

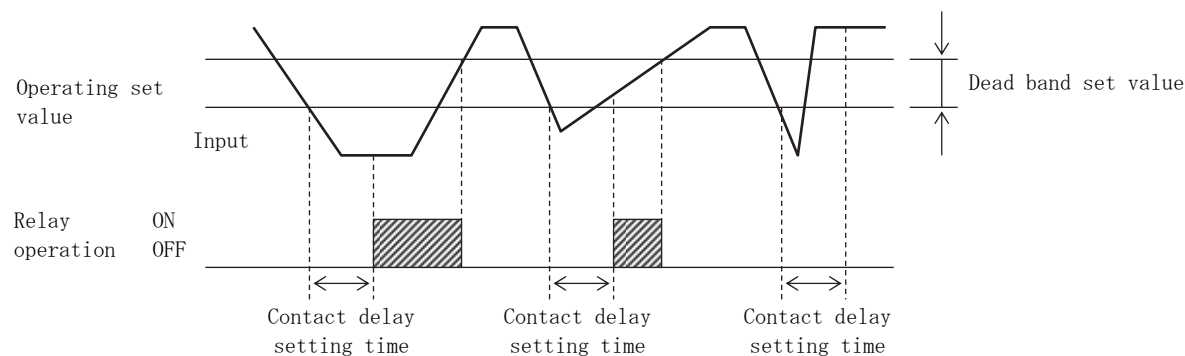





- About a contact delay function. (2-seconds delay operation instant return)



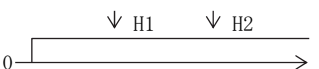
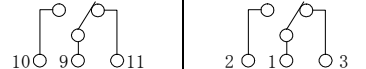
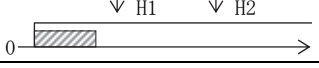

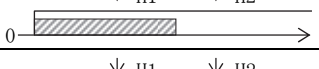
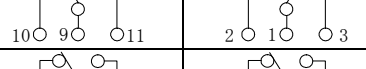
When an input continues for 2 seconds and exceeds an operation value, a contact operates for the first time. And, it returns at the same time it falls from an operation value. Operation of the contact by the momentary overload etc. can be prevented.

2.4 Operation of an alarm output ( : The state of an input)



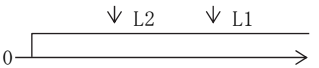
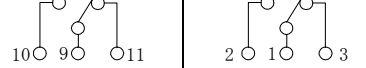
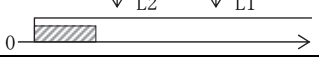

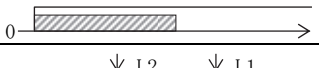

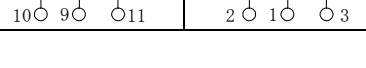

■ HH type

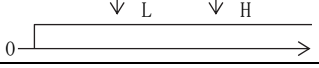
Power / Input	Illustration	ALARM	
		H1	H2
Power OFF			
Power ON Input < H1			
Power ON H1 ≤ Input < H2			
Power ON H2 ≤ Input			

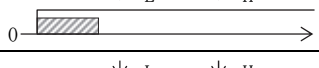

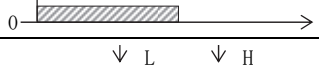
■ LL type

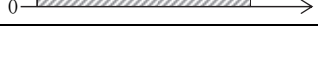
Power / Input	Illustration	ALARM	
		L2	L1
Power OFF			
Power ON Input ≤ L2			
Power ON L2 < Input ≤ L1			
Power ON L1 < Input			

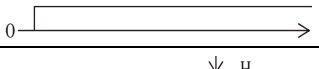
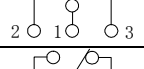

■ HL type

Power / Input	Illustration	ALARM	
		L	H
Power OFF			
Power ON Input ≤ L			
Power ON L < Input < H			
Power ON H ≤ Input			

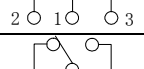
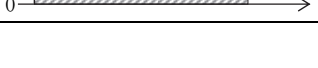
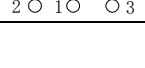
■ H type

Power / Input	Illustration	ALARM
Power OFF		
Power ON Input < H		
Power ON H ≤ Input		

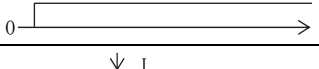
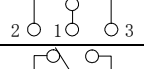
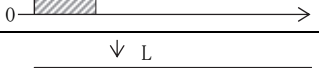
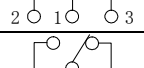
■ L type

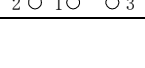
Power / Input	Illustration	ALARM
Power OFF		
Power ON Input ≤ L		
Power ON L < Input		

3. Handling explanation

3.1 Dimensions diagram (Unit mm)

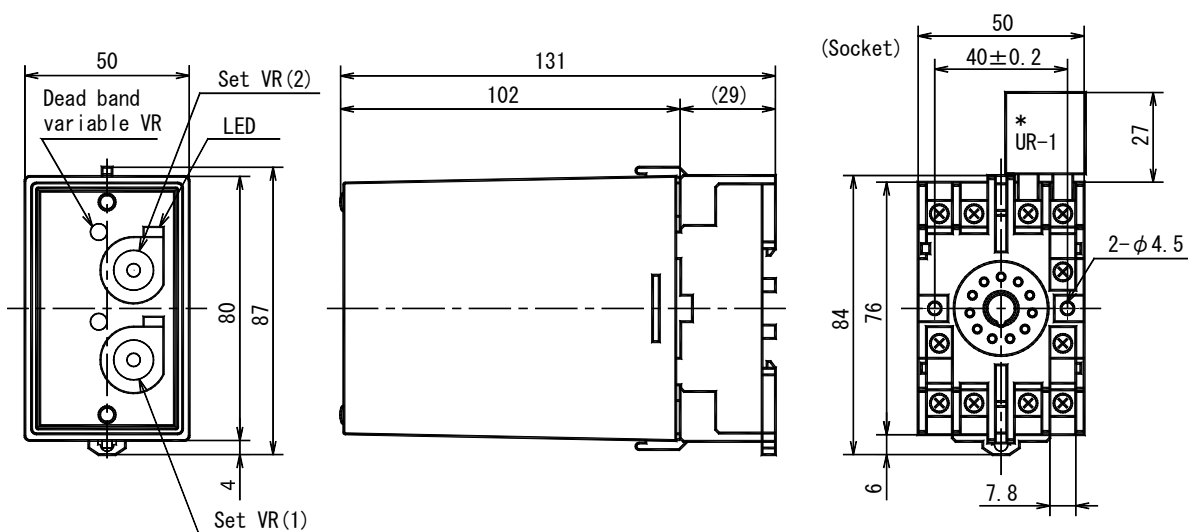

	Set switch (1)	Set switch (2)
HH type	H1	H2
LL type	L2	L1
HL type	L	H
H type	—	H
L type	—	L

* UR-1, Precision resistance unit. (Option)

Please use it combining the alarm setter of a voltage input. Please use it for the open measure at the time of exchanging an alarm setter. UR-1 is connected to a socket and a current signal is transformed into a voltage signal. (UR-1, Resistance is designated.)

3.2 Cautions on mounting.

Please select mounting space in the following environmental conditions on the occasion of mounting. Please mounting should select indoors with low mechanical vibration, little dust, and little corrosive gas. As for the mounting posture, there is not a limit especially. Mounting instruction can select 35mm width DIN rail mounting and screw mounting. Please get mounting with M4 screw. (But a screw is not attached. And give a binding fast torque of a screw as 1.08 to 1.47N·m) Should establish of side-by-side mutual mount space 5mm over. Top and bottom space considers wiring and space radiation of heat, and please establishes space more than 100mm. (Please reference to following.)

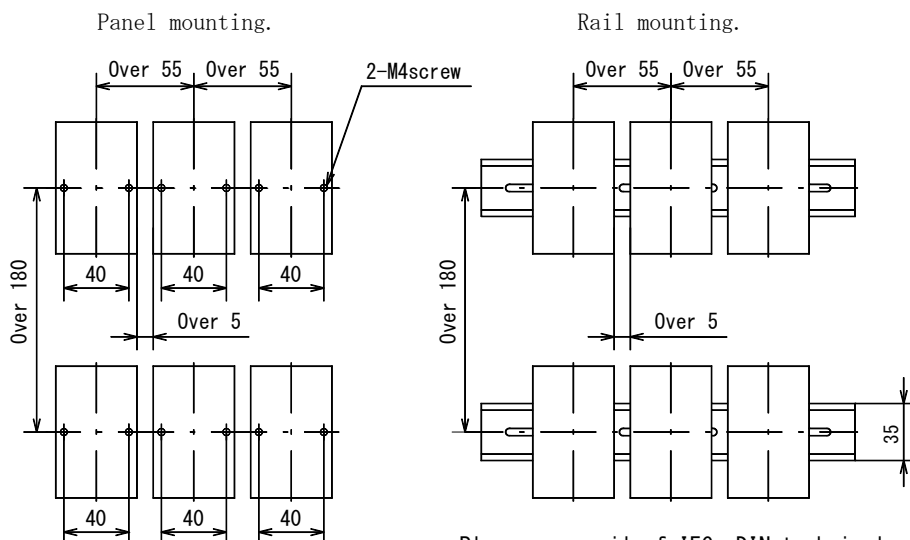

Please use rail of IEC, DIN technical standard 35mm width rail (reinforced type).

- Please prepare the installation space more than the above in consideration of radiation by the natural convection of air.
- If the duct for wiring is used, please detach 20mm or more from the upper surface and the undersurface of a mainframe.

3.3 Connection diagram

DC auxiliary supply.

AC auxiliary supply.

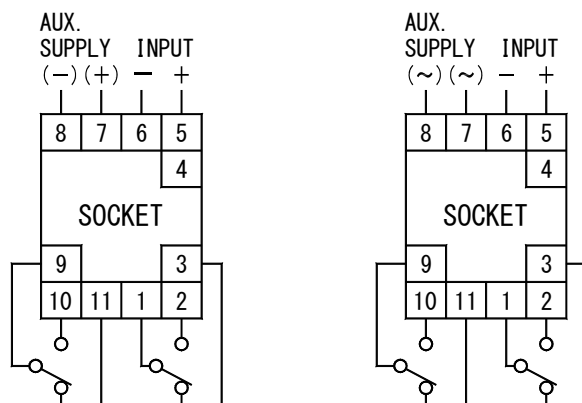

HH type	H1	H2
LL type	L2	L1
HL type	L	H
H type	-	H
L type	-	L

HH type	H1	H2
LL type	L2	L1
HL type	L	H
H type	-	H
L type	-	L

3.4 Cautions on connections

- (1) An external connection terminal is M3.5 screw terminal. Please use a solderless contact for connection with a terminal. The tightening torque of a terminal screw is 0.7 to 0.9N·m with M3.5 screw.
- (2) In case inductive loads (an electromagnetic relay) are connected to an output contact, we recommend you to use it near load like the example of the following figure, installing diode, a surge killer, etc.

《 The example of a spark quench circuit 》

(a) Only for DC

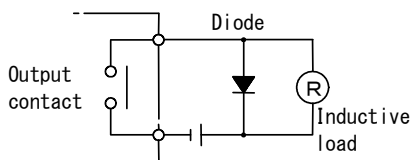

(b) AC/DC application

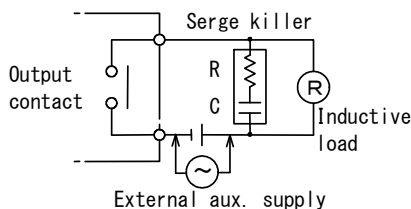

(c) AC/DC application

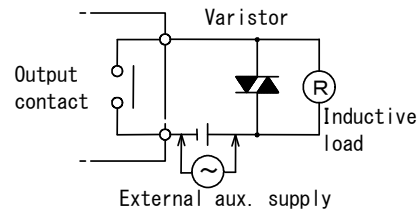

- (3) Connection with power supply or input applied is dangerous. Please be sure to work after intercepting a source.
- (4) If a terminal is touched at the case of cleaning or check, an electric shock will be received.
- (5) A burning accident may be caused by the wiring difference in a power supply or an input. Please be careful of wiring enough. And, check in the space which has combustibles, an inflammable medicine, inflammable gas, etc. in environment is also dangerous.

3.5 Cautions on installation

- Wiring state

Please separate wiring of input and output and consider to a noise. And, please detach the power line used as the source of a noise and steep voltage and current wire as much as possible. Especially, please use shielding wire for the bottom of the remarkable environment of a noise.

- Environmental conditions

Please give the ambient temperature and humidity under operation as a next range.
 Temperature : -10 to +55°C, Humidity : 30 to 85% RH (Non condensing)

3.6 Setting

(1) Setting of operation value.

Please set to a necessary operation value by the front real scale set VR.

Please do not turn set VR strongly. If it turns strongly, it damages and the right measurement becomes impossible.

<NOTE> If a set VR is operated in the state of a power supply apply, even if it does not exceed an operation value, a contact may operate. (They are not the abnormalities of a product.)

(2) Variable of dead band.

It can carry out dead band variable to 0.5 to 5% in dead band variable VR.

Please set to dead band according to the use environment.

4. Principle of operation

4.1 Block-diagram

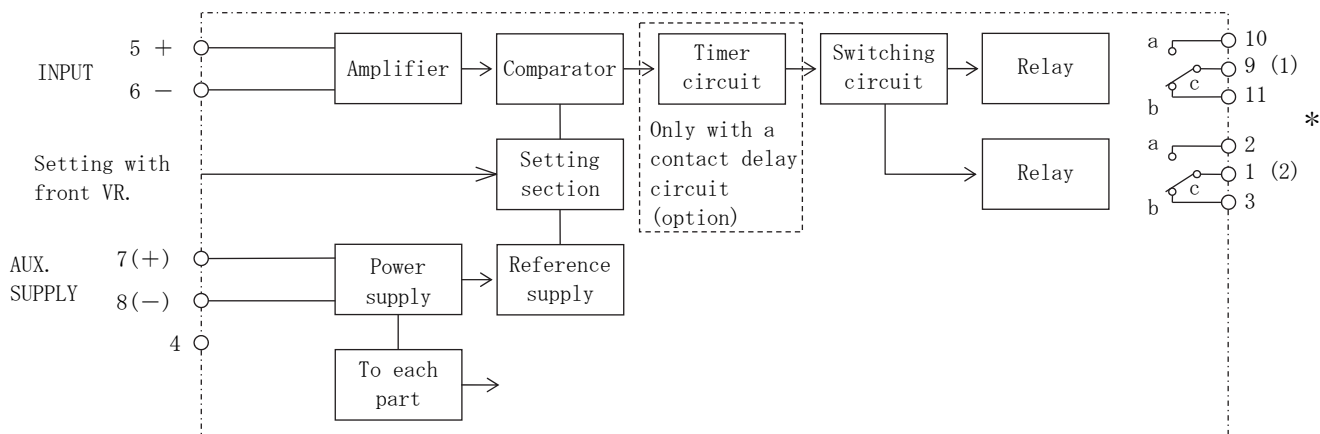

<NOTE> For specification without option, the timer circuit is not contained.

* Contact composition

TYPE	(1)	(2)
HH	H1	H2
LL	L2	L1
HL	L	H
H	-	H
L	-	L

4.2 Operating explanation

● With no option.

This product receives DC current or DC voltage, makes constant value amplify this, and is considered as the input of a comparator.

And, a partial pressure ratio is changed for a reference supply in the setting section's front VR.

Voltage comparison is performed for it as input of the comparator of another side.

The output operates a relay through a switching circuit.

● With an option. « Contact delay circuit »

This product receives DC current or DC voltage, makes constant value amplify this, and is considered as the input of a comparator. And, a partial pressure ratio is changed for a reference supply in the setting section's front VR. Voltage comparison is performed for it as input of the comparator of another side. It has opted for the start of a contact delay timer with the output.

A timer output operates a relay through a switching circuit after constant time efflux in a timer circuit.

5. Inspection, and calibration and maintenance

5.1 Receiving inspection

In case you inspect at the time of receiving, please carry out after consulting the following.

(1) Construction

Please carry out inspection of an outline dimension, mounting dimension, and an outside after referring to a dimension diagram.

(2) Performance

Please carry out a warm-up for 15 minutes after a power supply input applies. Then, please conduct performance inspection.

5.2 Periodic inspection

Please carry out the following way if needed.

Alarm output operation and setting accuracy : ON/OFF operation is normal, The accuracy of the operating point and a returning point (dead band) is tested.

Please set setting of an operation value to a necessary value in a front VR.

5.3 Maintenance

(1) The wiring change during the operation is dangerous.

(2) When you check it during the operation, please do not touch an input terminal and the power supply terminal.

(3) When checking input and a power supply, please check the electrical schematic.

(4) Please perform care by wiping with dry cloth. If a name-plate is wiped with solvents (alcohol etc.), an indication way may disappear.

5.4 Trouble shooting

Abnormal phenomenon	Cause presumed	Method of settlement
An output does not appear.	The power supply input is not applied.	Please auxiliary supply-input-check and apply.
	An alarm setter's failure.	Repair of an alarm setter.
	The input is not connected.	Please confirm connection of an input..
	The abnormalities of an input.	Please confirm an input value.
	The output is not connected.	Please confirm connection of an output.
	Auxiliary supply voltage is low.	Please confirm auxiliary supply voltage.
Operation LED does not turn on.	Auxiliary supply voltage is not regulation within the limits.	Please check auxiliary supply voltage and give as regulation within the limits.
	The input is not over set value.	Please check an input value.
	An alarm setter's failure	Repair of an alarm setter

5.5 Check

Although it is not necessary to check especially every day, please pay attention periodically to the next thing.

(1) It is confirmed whether a mainframe and socket combination are normal (is a lock a totality?).

(2) It checks for the slack of wiring, and the slack of a captive screw.

(3) Please remove, if dust has adhered to the case.

5.6 Storage

- (1) Please avoid storage in the next space. Low temperature, high temperature, high humidity, and sunny place
- (2) The aluminum electrolytic capacitor is used for a product.
Please do the energization of the power supply within one year after shipment.

5.7 Countermeasures against troubles

As our principle, we recall product in question and repair it. If judged as product failure, have a contact with us or sales agent for repairing work (Also have a contact with us or sales agent for specification change). Product failure which we are not responsible for (when responsibility in manufacturing process is not recognized, when product is disassembled/remodeled, in case of false operation by customer, etc.) is beyond our warranty.

 **DAIICHI ELECTRONICS CO., LTD.**

Tokyo Office : 11-13, Hitotsuya 1-chome, Adachi-ku, Tokyo, 121-8639, JAPAN.
TEL : +81-3-3885-2411 , Fax : +81-3-3858-3966

Kyoto Office : 1-19, Ichinobe-Nishikawahara, Jyoyou-shi, Kyoto, 610-0114, JAPAN.
TEL : +81-774-55-1391 , Fax : +81-774-54-1353

Revision B, DATE : December 19, 2014