

AC AMMETER / VOLTMETER

(Moving Iron Type)

PSD-96

Ammeter

Normal scale Max. scale value	Extended scale				Approx. consumption VA	Accessory
	2-time	3-time	4-time	5-time		
100mA	200mA	300mA	400mA	500mA	1VA	—
1A	2A	3A	4A	5A		
3A	6A	9A	12A	15A		
5A	10A	15A	20A	25A		
10A	20A	30A	40A	50A		
15A	30A	45A	60A	75A		
20A	40A	60A	80A	100A		
30A	60A	90A	120A	150A		
5 / 5A ⁽¹⁾	10A	15A	20A	25A	1VA	—
∫	∫	∫	∫	∫		
10k / 5A	20kA	30kA	40kA	50kA		

Note:

⁽¹⁾ When 30A or 600V in circuit voltage is exceeds, current transformer (CT) will external to meter 5A (0.1A,1A).

For SCR control waveform

Meter SCR waveform input (distorted waveform) can be manufactured.

Model Name: PSD-96H-□

* Meter for 400Hz also can be manufactured.

Voltmeter

Max. scale value	Approx. consumption VA	Accessory (series resistor)
50V ∫ 300V	5VA	—
600V ⁽¹⁾	10VA	DM-41
600/ 150V ⁽²⁾ ∫ 550k/ 150V	5VA	—

Note:

⁽¹⁾ Scale value between 301~600V will external with DM-41.

⁽²⁾ When 600V is exceeds, voltage transformer (VT) will external to meter 150V.

For SCR Control Wareform

Meter SCR waveform input (distorted waveform) also can be manufactured.

Model name: PSD-96H-□

AC AMMETER / VOLTMETER (Moving Iron Type)

PSD-96

Connection Diagram

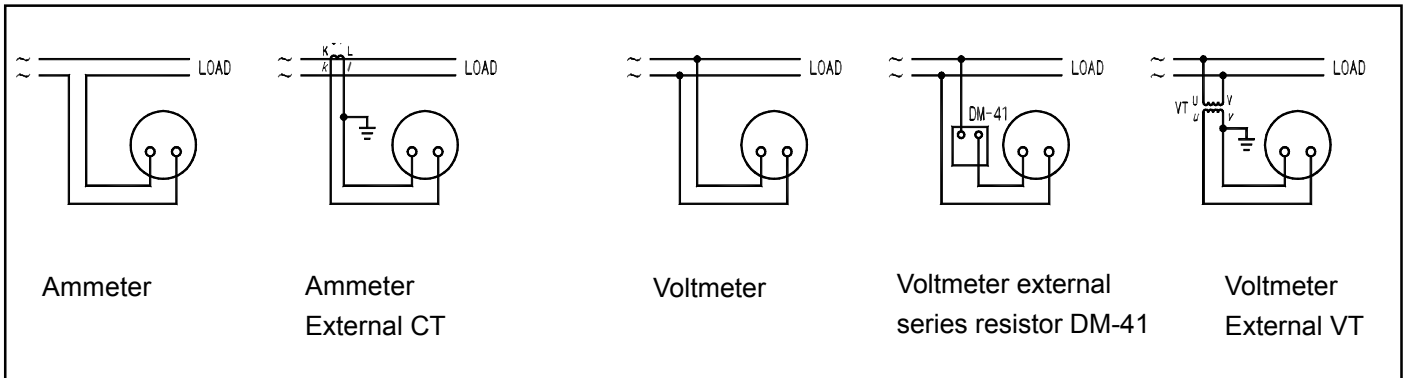

Dimensions

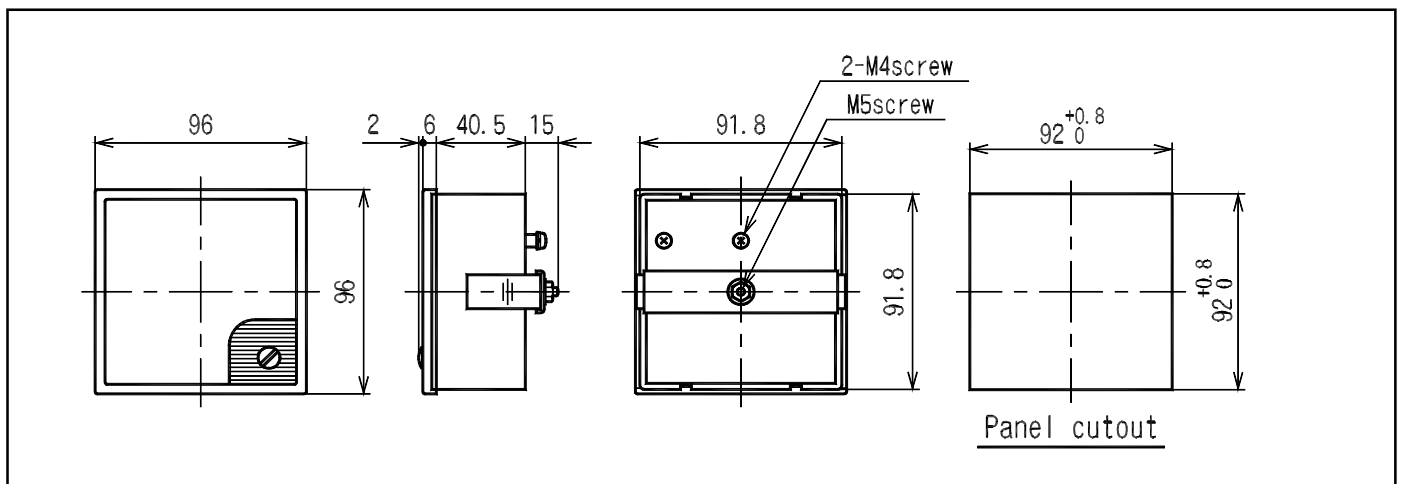

Dimensions for DM-41

